

WESMAR™

WESTERN MARINE ELECTRONICS

English | Español | 中文 | Русский

14120 NE 200th Street
Woodinville, WA 98072-4001 - USA
Phone: 425-481-2296 Fax:425-486-0909



[HOME](#) [PRODUCTS](#) [CUSTOMER SERVICE](#) [DEALER INFORMATION](#) [NEWSROOM](#) [ABOUT US](#) [CONTACT](#) [JOB OPPORTUNITIES](#)

Sonar Systems Division

Mechanical Systems Division

Defense Systems Division

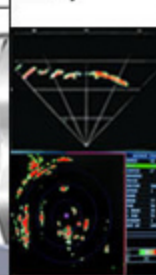
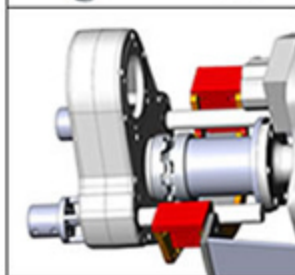



WESMAR EV850 Expedition Vessel Navigation and Security Sonar

David V. Pollon

Sales Manager, Yacht Sonar Products

WESMAR

Western Marine Electronics

+1 (425) 481-2296

dpollon@wesmar.com

www.wesmar.com

About WESMAR

- Founded in 1965 by President Bruce H. Blakey
- An innovative American product design, development and manufacturing company
- Product firsts: solid-state sonar, counter-rotating bow thruster, electronic gyro roll-fin stabilizers
- Our products are built in WA state, and exported throughout the world

Threats – Decreasing Security



- December 2008
 - M/V Ocean Nautica chased by pirates in the Gulf of Aden
- Wall Street Journal, November 2008
 - “...piracy has experienced a meteoric rise, with the number of attacks increasing by double-digits per year.”
 - “Pirates off the Somalia coast have attacked 26 vessels and taken hostage 537 crew members in the three months ended Sept. 30 (2008)”
 - “Attacks on Shipping in Mideast raise Insurance Costs.”
- Counterterrorism – A Reference Handbook (Author: Graeme Steven)
 - “Anchored or berthed ships, especially when in port are vulnerable to underwater attack...”

Threats – Hazards to Navigation



- July 2008
 - Nine hour stranding of the *M/V Spirit of Glacier Bay* near Glacier Bay National Park in Alaska
- November 2007
 - Sinking of the *M/S Explorer* off Antarctica after ice created a hole the size of a fist in the hull

The WESMAR EV850 Expedition Vessel Navigation and Security Sonar

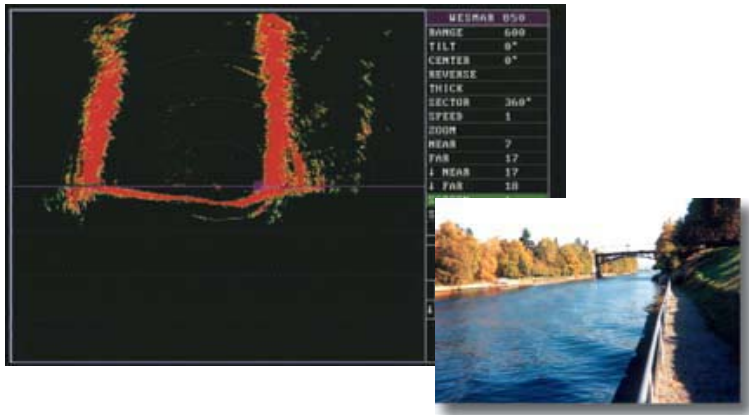

- Safety while cruising in unknown or hazardous waters
- Scanning of harbor entrances
- Constant sonar monitoring of depth under vessel to prevent groundings
- 360 degree detection of underwater intruders

EV850 Features



- The EV850 protects your vessel investment with WESMAR sonar technology that has been proven in commercial fisheries and military deployments
 - Active electronic gyro controlled stabilization, capable of correcting 34 degrees of movement per second
 - 110 kHz frequency for high resolution, effective for both navigation and underwater intruder detection
 - New large array transducers provide greater transmit power and receiving sensitivity
 - Joystick operation for simplified operation
 - Robust hydraulic hoist system

EV850 Architecture

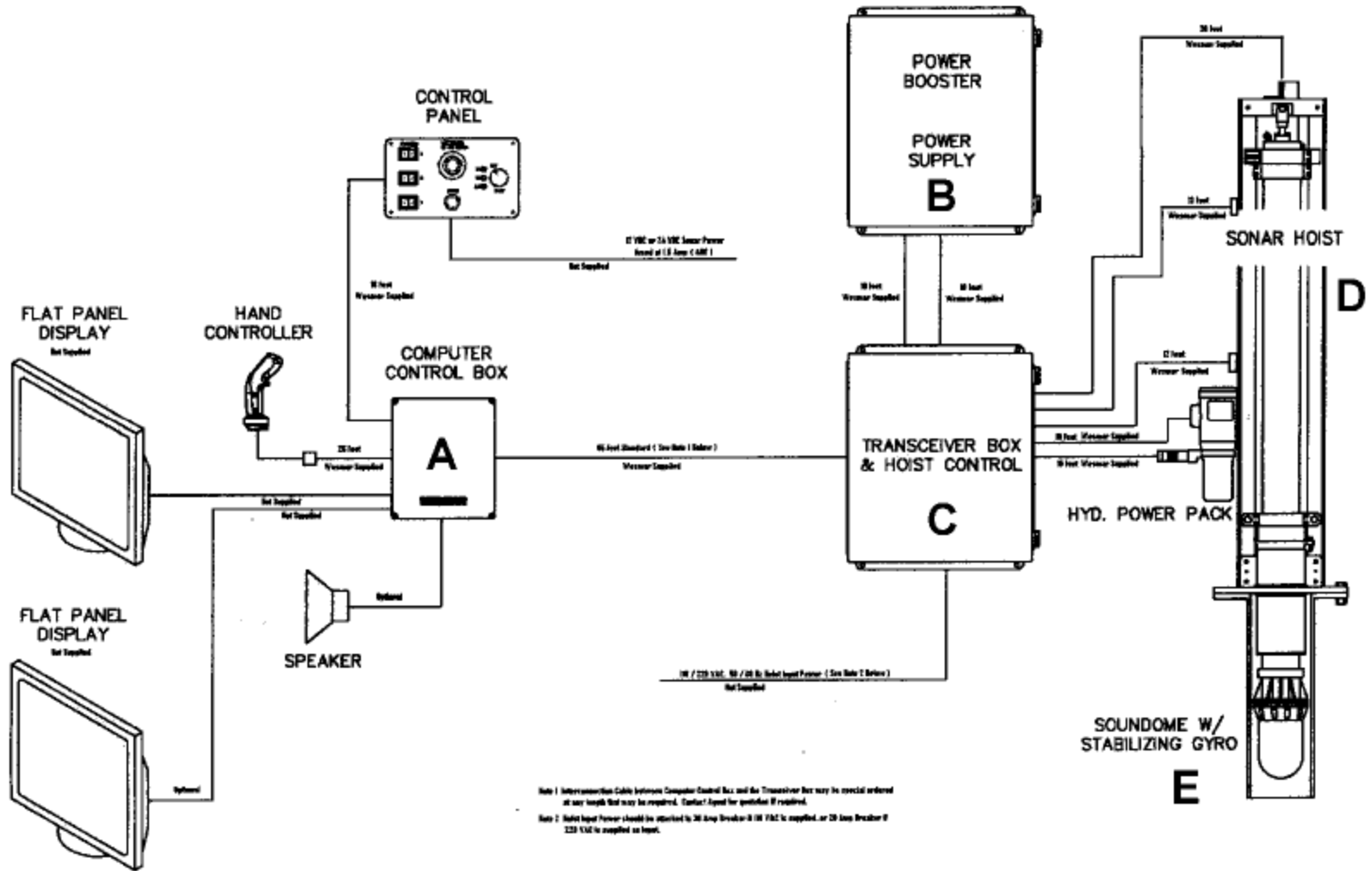

Lindblad Expeditions

“All cruise ships should have the WESMAR sonar for navigation...It’s like an underwater radar.”

[Capt Leif Skog, M/S National Geographic Explorer]



Contact Us



WESMAR

Western Marine Electronics

14120 NE 200th Street

Woodinville, WA 98072 USA

www.wesmar.com