



# HD800/110-10 SPECIFICATIONS with M18 Hydraulic Hoist

January 2003

## A. CONTROL UNIT

### 1. Presentation

High resolution output, 640 x 480 pixels  
8 or 16 colors depending on echo strength

### 2. Sonar Display

- (1) Full screen sonar
- (2) Full screen bottom profile
- (3) Split screen sonar and profile
- (4) Vertical fish profile mode
- (5) Full screen stabilized video sounder

### 3. GPS Tracking

Track moving targets when GPS is connected

### 4. Dual Controls, for Split Screen

- |                  |                      |
|------------------|----------------------|
| (1) Range        | (7) Threshold        |
| (2) Near Gain    | (8) Scanning Speed   |
| (3) Far Gain     | (9) Scanning Sector  |
| (4) TVG          | (10) Colors, 8 or 16 |
| (5) Power        | (11) Delete Colors   |
| (6) Pulse Length |                      |

### 5. Transducer Control

- (1) Tilt, + 4° to - 90°, in 1° steps
- (2) Scan, adjustable sectors,  
Stepping speeds 1.8° to 21.6°

### 6. Console Voltage

12 - 32 VDC, 36 W

### 7. Audio Output

Proportional to echo strength  
Horn Speaker

## B. TRANSMIT RECEIVE UNIT

1. Power Output: 1.6 kW
2. 6 Stage, Low Noise Receiver

## C. HOIST UNIT

1. Height: 1482 mm (58.3 inch)
2. Travel: 800 mm (31.2 inch)
3. Retraction Time: 5 seconds
4. Electric Motor : 2 HP 110 VAC or 220 VAC
5. Flange: 10 inch steel, 25 mm thick
6. Soundome Tube: Stainless steel, 168 mm O.D. (6.6 inch)

## D. SOUNDOME UNIT:

1. Frequency: 110 kHz
2. Soundbeam: 5° Vertical, 9° Horizontal  
Stabilized
3. Soundome Boot: Urethane
4. Soundome Flange: Stainless Steel
5. Diameter: 248 mm (9.5 inch)

## E. SEACHEST - (Customer Supplied):

1. Length: 900 mm (35.4 inch) minimum
2. Pipe: 10 inch, Schedule 60
3. Flange: Standard, 10 inch

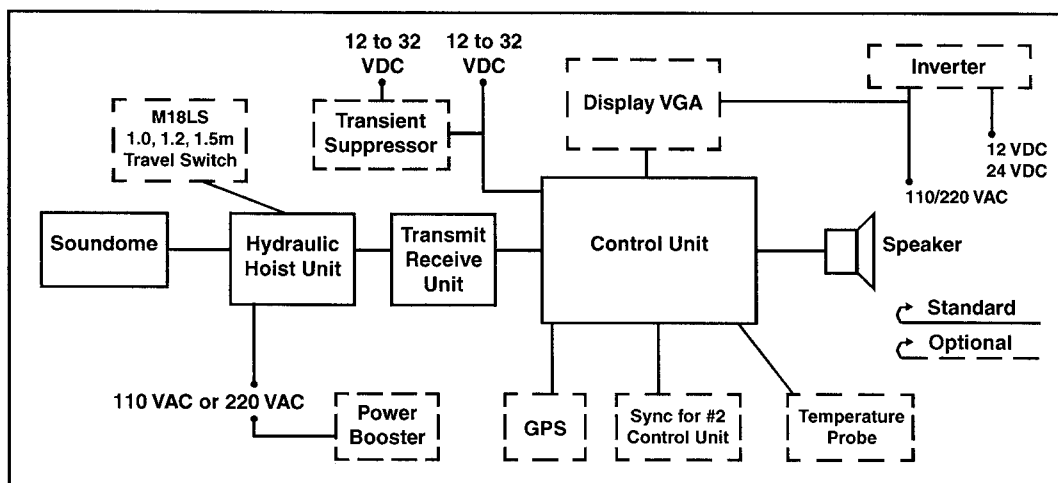

# WESMAR

DEFENCE PRODUCTS

SONAR MODEL 3110-10

HOIST MODEL M-18

## CONSOLE

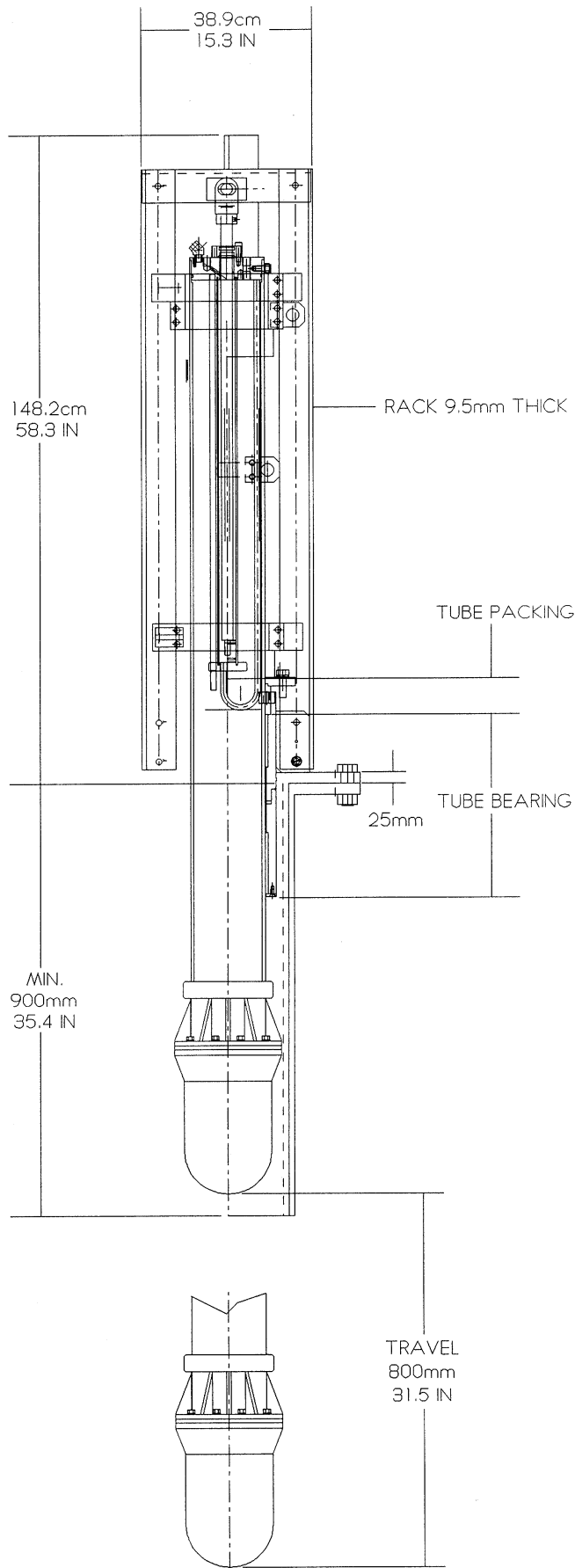
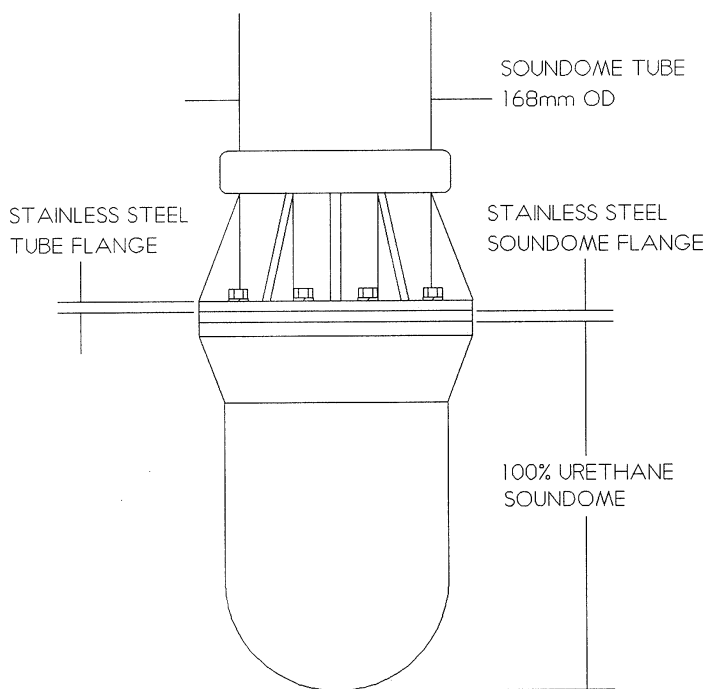
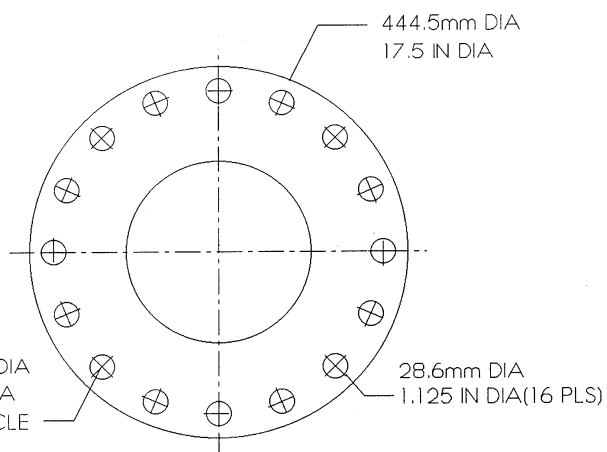
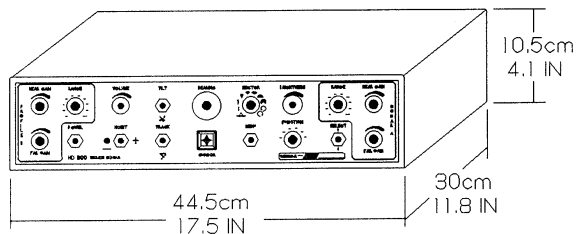

# WESMAR

DEFENCE PRODUCTS

SONAR MODEL 3110-10

HOIST MODEL M-18

## CONSOLE

