

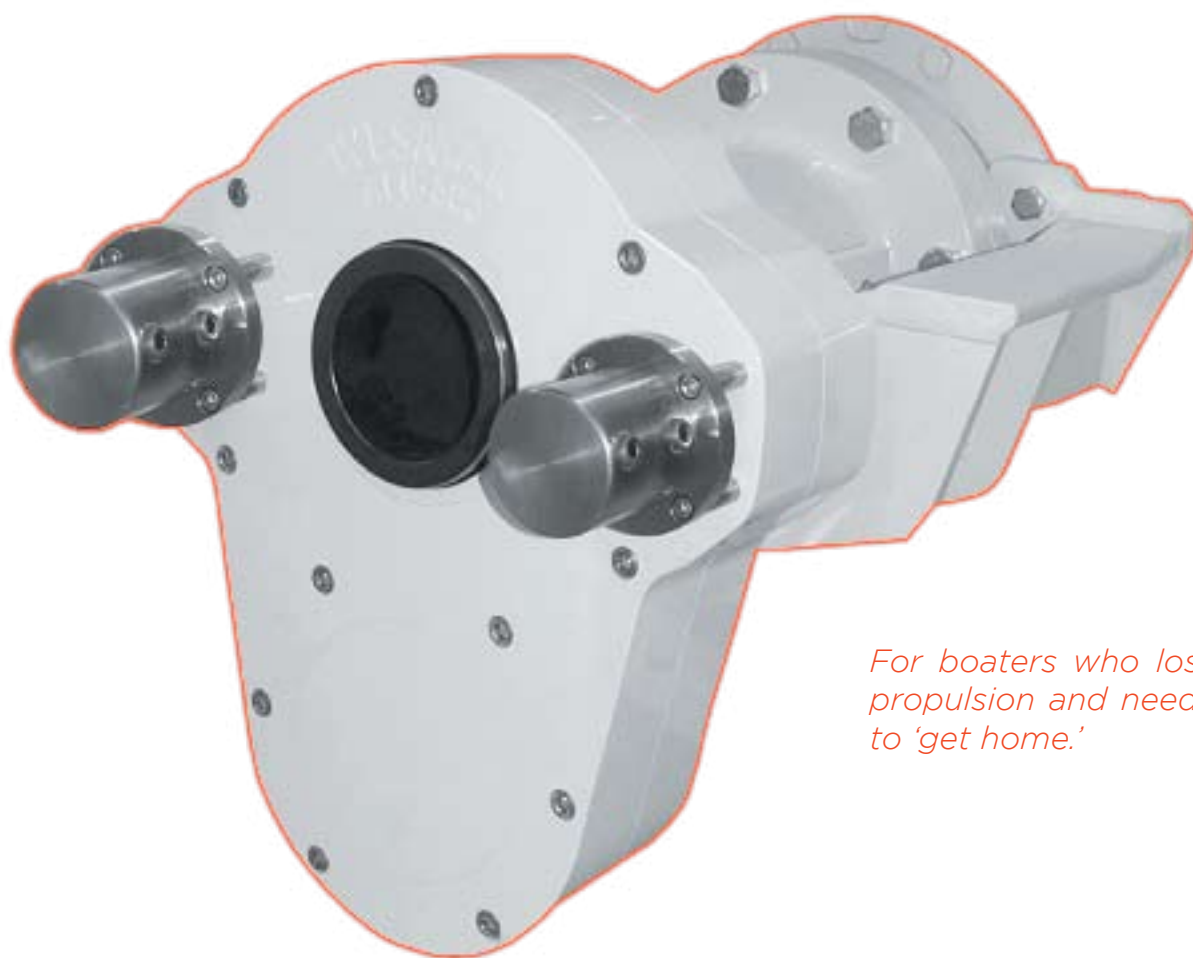

WESMAR™ APU

AUXILIARY PROPULSION UNIT

Peace of mind for single screw vessels



For boaters who lose their propulsion and need a way to 'get home.'

INSTANT, RELIABLE, ALTERNATIVE SOURCE OF POWER

Easy to Engage right from the Helm

Leave engine failure worries to the WESMAR APU System

WESMAR's Auxiliary Propulsion Units come in two sizes the APU Model 200 and the APU Model 300. They offer an instant, reliable alternative source of power with minimal maintenance.

Powered by your vessel's generator or stand-alone engine, the APU allows fuel efficient, continuous operation, giving the ability to bring the boat to port in the event of mechanical failure, and the ability to quietly cruise without the use of the main engine. Simplicity and practicality are the focus of this 'get-home' system.

The compact, rugged design of the APU ensures reliability with robust, corrosion-resistant operation. And, as with all WESMAR products, the APU is built of the most durable materials and powder coated to ensure a long life.

The APU Automatically Engages from the Helm

In Standby

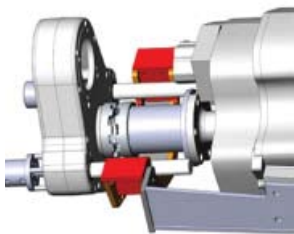

Helm Control



Engaged and ready for operation

System Features

- Provides continuous propulsion in the event of a main engine failure.
- Low shift RPM for trolling, maneuvering, and sight-seeing.
- Quiet operation for late night and early morning departures resulting in minimal disturbances to guests and neighbors.
- Quiet trolling speeds for fishing.
- The APU can be a dedicated hydraulic unit, and also fits perfectly with WESMAR's other hydraulically driven products, which are uniquely designed to improve comfort and control for boaters around the world.
- Operates with a helm-mounted safety key lock.



Complete control from the helm using state-of-the-art electronics. The WESMAR APU systems can be operated right from the bridge by simply turning the key and using the proportional joystick for forward and aft propulsion. Once the system is engaged with the key lock at the helm, it is activated and you are immediately in control and underway. No need to visit the engine room at all.

APU System Design

Two APU Models: APU Model 200 and Model 300

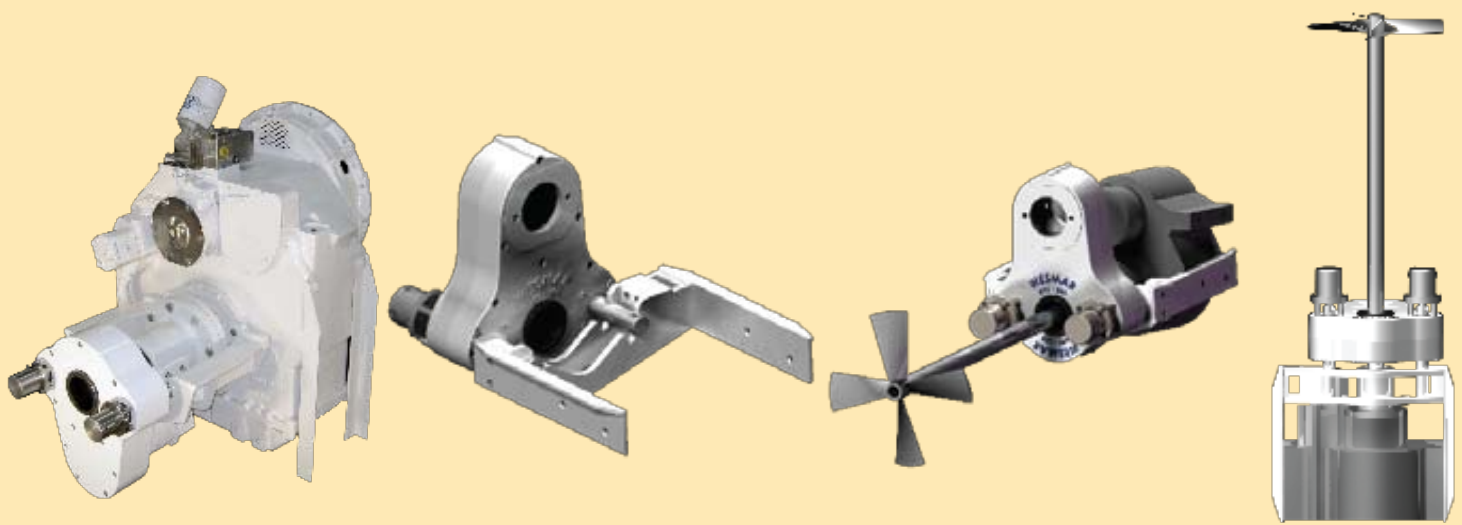

APU Model 200

Maximum HP Rating

25HP/19kW

Maximum Propeller Shaft Diameter

2.38 inches/60.45mm

APU Model 300

Maximum HP Rating

100/75kW

Maximum Propeller Shaft Diameter

3.38 inches/85.85mm

**For a no-obligation quote, send transmission make and model, shaft diameter, generator KW rating, PTO size, prop diameter and pitch to cjones@wesmar.com.*

APU Patent # US6558209

For Vessels without Central Hydraulics Systems

Optional 10 Gallon Hydraulic Reservoir Tank With Centralized Components Vertical or Horizontal Setup

Hydraulics Tank Design Leads the Industry.

WESMAR's advanced design hydraulic tank incorporates hydraulic manifold, high-pressure filter and cooler in one system. They are all mounted and plumbed together. The use of centralized components greatly reduces installation time and potential for error.



SAE-A 2 bolt
SAE-B 2-bolt
or SAE-C 4-bolt



Optional Hydraulic Pump

Standard Systems and Options

- APU Drives
- Hydraulic Motor Shaft Coupling Arrangement
- On-Off Key Lock
- Friction Joystick for Forward and Aft Propulsion
- Engagement, Shift & Alarm Indicators
- WESMAR Hydraulic Reservoir (Optional)
- Hydraulic Pump (Optional)
- Hydraulic Proportional Valve (Optional)

Standardize with WESMAR Products

WESMAR brings over four decades of design and manufacturing to the marine industry, providing equipment to commercial, private and government operations around the world. WESMAR's network of support includes over 350 trained service personnel, dealers and distributors who are dedicated to customer support. The APU systems join a wide range of roll fin stabilizers, hydraulics systems and rugged bow and stern thrusters.



•ROLL FIN STABILIZERS

WESMAR's cutting-edge roll fin stabilizers vastly improve vessel handling and safety, save fuel, and provide exceptional comfort for passengers and crew. WESMAR's stabilizers electronically adjust to correct up to 90% of rolls, resulting in more efficient and relaxed traveling.



•ANCHOR WINDLASS

WESMAR's stainless steel anchor windlass is uniquely designed with an electronically driven magnetic chain counter that is imbedded in the housing. Low maintenance and reliable operation of all stainless steel hardware are the primary objectives behind WESMAR's anchor windlass.



•STAINLESS STEEL BOW AND STERN THRUSTERS

WESMAR's dual prop counter rotating bow and stern thrusters offer up to 40% more thrust than standard single prop thrusters. With sizes from 12" to 36" with varying horsepower from 5 to 600 your application is covered.

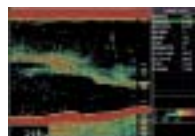

•FISH DETECTION, NAVIGATION AND SECURITY SONAR

WESMAR's wide range of precision searchlight sonar, designed for yachts and sportfishing boats, gives 360 degrees of detailed information beneath and around the vessel. WESMAR's high tech sonar is a must for every vessel on the open water for unequaled fish detection, navigation, and safe travel.



WESMAR Western Marine Electronics

Telephone: (425) 481-2296 • Fax: (425) 486-0909
E-mail: bsentz@wesmar.com • www.wesmar.com

PRODUCT WARRANTY

Commercial warranty and consumer limited warranty, disclaimer, and remedies. Seller warrants title, materials, and workmanship on equipment, except components manufactured by others for which seller assigns, as permitted, the original manufacturer's warranty. Seller's warranty period for all applicable express or implied warranties shall be ninety (90) days after installation or one (1) year after date of shipment to the original buyer, whichever time period expires first. Nonconforming equipment reported to seller during the applicable warranty period and returned to seller at buyer's expense and risk shall be repaired, or replaced at seller's option. If seller is unable or unwilling to repair or replace such reported and returned nonconforming equipment within a reasonable time, then buyer shall be entitled to a refund of the purchase price of the equipment as buyer's sole remedy. This paragraph sets forth buyer's exclusive remedies for nonconforming goods. This commercial warranty and consumer limited warranty is in lieu of all other warranties, express or implied, including design, course of dealing, merchantability, and fitness for a particular purpose.

NOTE: LIMITATION OF SELLER'S COMMERCIAL AND CONSUMER LIABILITY. Seller shall not be liable on any claim for loss of use, revenue, or profit, for injury, or for any other incidental or consequential damages, regardless of the basis for buyer's claim(s), including, but not limited to, the law of contract, warranty, or tort. In no case shall seller's liability on any claim(s) exceed the amount paid to seller for the purchased goods.